



FRANKA PRODUCTION 3

Datasheet

Datasheet ¹

Arm & Control

ARM	
Degrees of freedom	7
Payload	3 kg
Maximum reach	855 mm
Force/Torque sensing	link-side torque sensor in all 7 axes
Joint position limits	A1, A3: -166/166 deg A2: -105/105 deg A4: -176/-7 deg A5: -165/165 deg A6: 25/265 deg A7: -175/175 deg
Mounting flange	DIN ISO 9409-1-A50
Installation position	upright
Weight	~ 17.8 kg
Protection rating	IP40
Air humidity	20 – 80 % non-condensing
Interfaces	<ul style="list-style-type: none"> • ethernet (TCP/IP) for visual intuitive programming with Desk • safety-rated input for external enabling device • 2 configurable safety-rated inputs for emergency stop devices, safeguards or other protective devices (OSSD devices via external OSSD converter connectable) • hardware prepared for: 2x DI & 2x DO (24V, isolated, EN 61131-2 type 3 characteristics, 100 Hz sampling rate) • Control connector • connector for end effector
User Interfaces at the Arm's Pilot Grip	<ul style="list-style-type: none"> • integrated safety-rated guiding enabling switch • guiding button • guiding mode selector
User Interfaces at the Arm's Pilot Disc	<ul style="list-style-type: none"> • status light • Pilot mode selector • arrow keys, teach, confirm, delete
CONTROL	PERFORMANCE
Controller size (19")	355 x 483 x 89 mm (D x W x H)
Supply voltage	100 – 240 V _{AC}
Mains frequency	50– 60 Hz
Power consumption	~ 80 W
Active power factor correction (PFC)	yes
Weight	~ 7 kg
Protection rating	IP20
Air humidity	20 – 80 % non-condensing
Permitted mounting orientation	horizontal
Interfaces	<ul style="list-style-type: none"> • ethernet (TCP/IP) for internet and/or shop-floor connection • power connector IEC 60320C14 (V-Lock) • Arm connector
Motion	Joint velocity limits A1-A4: 150 °/s A5-A7: 301 °/s Cartesian velocity limits up to 2 m/s end effector speed Pose repeatability ² <+/- 0.1 mm (ISO 9283)
Interaction	Guiding force ~ 2.5 N Adjustable translational stiffness 10 – 3000 N/m Adjustable rotational stiffness 1 – 300 Nm/rad Monitored signals joint position, velocity, torque cartesian position, force
ADD-ONS	
Fully integrated end effectors	<ul style="list-style-type: none"> • 2-finger gripper • Vacuum gripper
Fieldbuses	<ul style="list-style-type: none"> • Modbus/TCP • OPC UA

SAFETY

Compliance

EN ISO 10218-1:2011 Robots and robotic devices - safety requirements for industrial robots Part 1: Robots

EN ISO 13849:2015 safety of machinery - safety-related parts of control systems

Collaborative operation modes

Safety-rated monitored stop	fully integrated in PL d Cat. 3
Hand-guiding	fully integrated in PL d Cat. 3
Safety-rated speed and separation monitoring	realizable in combination with external protective devices up to PL d Cat. 3

Safety parametrization & validation

Watchman	user interface to set and validate safety-related parameters
User management	role based access management

Safety Functions

Emergency Stop (X3.1)	PL d / Cat. 3
External Enabling Device (X4)	PL d / Cat. 3
Enabling Button	PL d / Cat. 3
Two configurable safe inputs (X3.2 and X3.3)	PL d / Cat. 3
SLP-C: Safely limited Cartesian position	PL d / Cat. 3
SLS-C: Safely limited Cartesian speed	PL d / Cat. 3
SLP-J: Safely limited joint angle	PL d / Cat. 3
SLS-J: Safely limited joint speed	PL d / Cat. 3
SLD: Safely limited distance	PL d / Cat. 3
SEEPO: Safe End Effector Power off	PL b / Cat. b

Stopping Functions

Category 0 stop	PL d / Cat. 3
Category 1 stop	PL d / Cat. 3
Category 2 stop	PL d / Cat. 3

1. Technical data are subject to change.

2. Based on ISO 9283 (Annex A), specified values refer to a workspace of 0.4 x 0.4 x 0.4 m centered at [0.498, 0.0, 0.226] m, with the Z-Axis of the flange oriented parallel to earth-gravity and the elbow positioned upwards.

DIMENSIONS & WORKSPACE

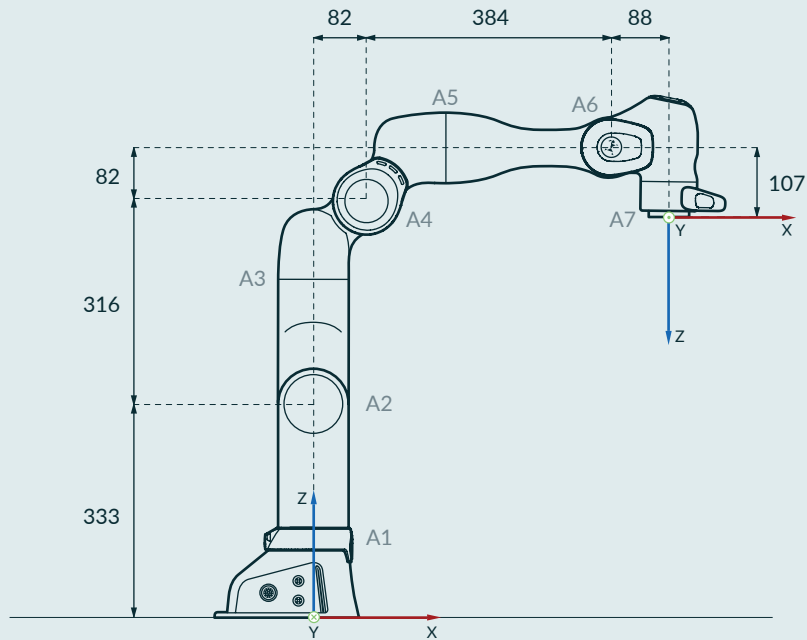

Axes names with joint lengths [mm]

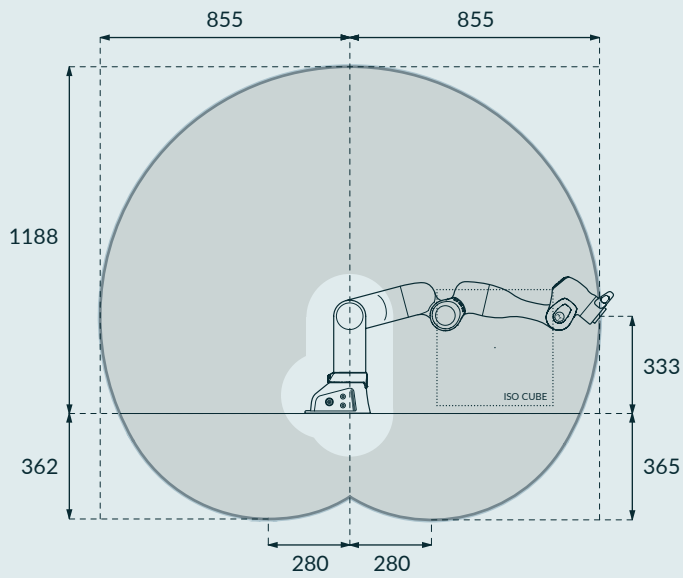

Workspace | side view [mm]

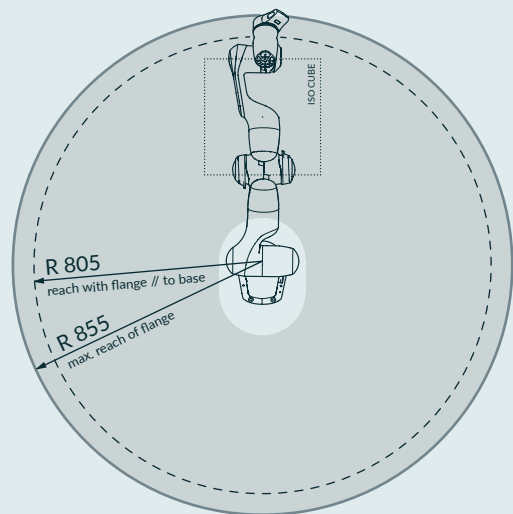

Workspace | top view [mm]